



AIRCCLASSICS®

Flight Timer

TIMER-3



USER'S MANUAL

Features	2	Chronograph Function	9
Controls and Indicators	4	Chronograph Operation	9
Display	4	Approach Timer Function	9
Buttons	4	Selecting an Approach Time	10
Parts and Assembly	4	Count-up Operation	10
Getting Started	4	Countdown Operation	10
Battery Replacement	5	Approach Timer Alarm	11
Button Functions	5	Canceling the Approach Timer Alarm ..	11
Clock Function	6	Recalling Stored Approach Times	11
Display Formats	6	Note/Scratchpad Function	11
Setting Time	7	Backlight Operation	12
Setting UTC Hour	7	Device Reset	12
Fuel Timer Function	7	Care	12
Count-up Operation	8	Specifications	12
Countdown Operation	8	Limited Warranty	13
Fuel Timer Alarm	8		
Canceling the Fuel Timer Alarm	8		

Congratulations on your purchase of the Flight Timer from Aviation Supplies & Academics, Inc. (ASA). This is a quality timekeeping instrument engineered to meet the needs of pilots. We hope you enjoy the functionality and convenience of your new Flight Timer.

FEATURES

- ▶ Large, readable LCD display
- ▶ Uniform LED backlight preserves night vision
- ▶ Auto shut-off backlight extends battery life
- ▶ Multi-function clock:
 - Standard time (AM/PM)
 - Military time (24-hour)
 - Universal coordinated time (UTC or “Zulu”)
- ▶ Allows simultaneous timing of three events
- ▶ Stopwatch with 1/10th and 1/100th second digits
- ▶ Fuel timer notifies you when to switch fuel tanks
- ▶ Approach timer stores 12 approach times
- ▶ Audible and visible alarms
- ▶ Intuitive push and rotate dial sets times quickly
- ▶ 5-digit note can remember important flight numbers
- ▶ Low battery indicator
- ▶ Multiple mounting options:
 - Clips onto flight board
 - Hook & loop attaches to panel or yoke clip
- ▶ Uses two AAA batteries (included)
- ▶ Sleek, ergonomic design
- ▶ Count-up or countdown timer function

Flight Timer

TIMER-3

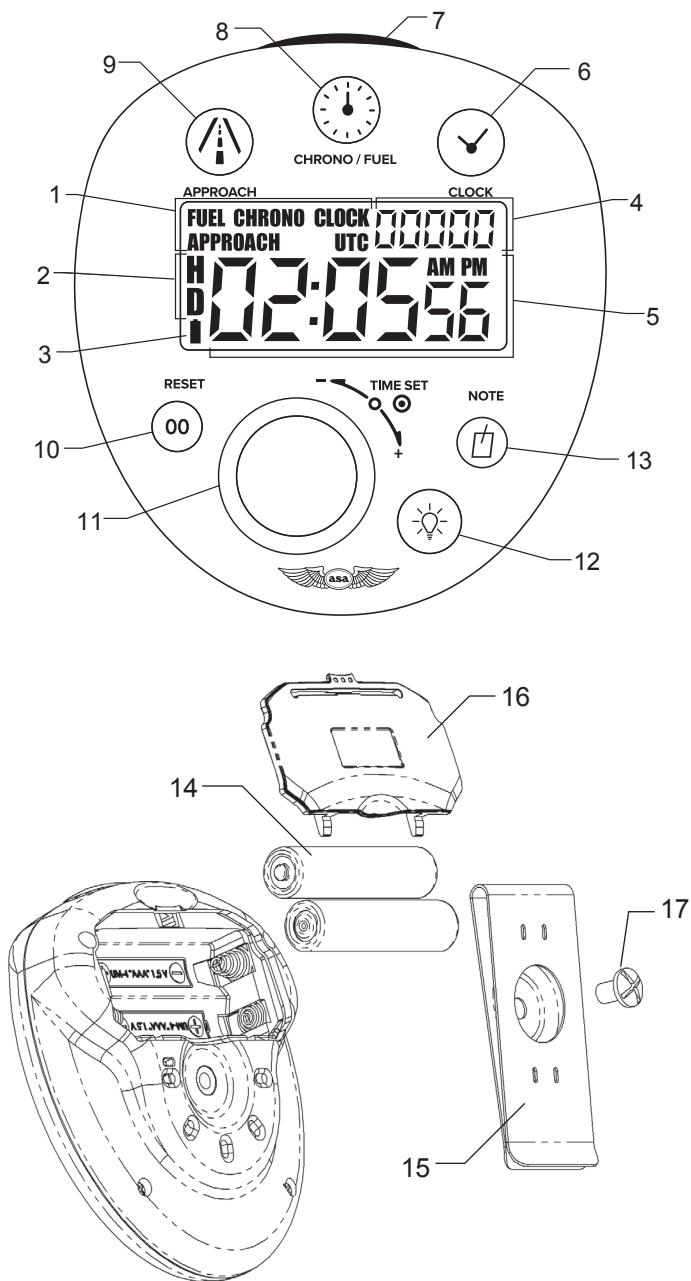

Figure 1—Display, buttons, and parts (see legend on next page)

CONTROLS AND INDICATORS

Display

1. Mode indicators
2. Home/Destination approach time memory banks
3. Low battery indicator
4. 5-digit note scratchpad
5. Clock and timer display

Buttons

6. CLOCK
7. START/STOP
8. FUEL/CHRONO
9. APPROACH
10. RESET
11. DIAL
12. BACKLIGHT SWITCH
13. NOTE

Parts and Assembly

14. 2 AAA alkaline batteries
15. Mounting clip
16. Battery cover
17. Metric clip screw (M4 x 0.8mm)

GETTING STARTED

To begin using your Flight Timer, turn the timer over and remove the battery tab. Install the 2 AAA alkaline batteries included in the package according to polarity diagram.

Note: The Timer is intended to function effectively within an extensive span of atmospheric conditions. However, if subjected to direct sunlight or excessive temperatures for a prolonged period of time, the display may go black or you may see a rainbow effect (most visible when wearing polarized sunglasses). If this happens, remove the timer from the heat and sunlight, and it will display correctly after several minutes.

BATTERY REPLACEMENT

Follow these steps to replace the batteries:

- ▶ Turn the mounting clip to a horizontal position.
- ▶ Press snap tab down and remove battery cover.
- ▶ Install 2 AAA alkaline batteries according to polarity diagram.
- ▶ Check to see that timer display is on.
- ▶ To reinstall battery cover, insert bottom lugs first then snap into place.
- ▶ Timer is ready for use.

BUTTON FUNCTIONS

CLOCK (6)—Displays time. Multiple presses toggle between standard time (AM/PM), military time (24-hour), and universal coordinated time (UTC or “Zulu”).

FUEL/CHRONO (8)—Jumps to fuel timer from any other mode. Subsequent presses toggle between fuel and chrono (stopwatch) modes.

APPROACH (9)—Jumps to approach timer from any other mode.

NOTE (13)—Press to set note data.

START/STOP (7)—Starts a stopped timer, stops a started timer. Also stops the audible and visible alarm for the currently displayed timer.

DIAL (11) push—Pushing the dial knob allows the current timer, clock or note data to be set. Flashing digits indicate the current digits being modified. Subsequent presses step through the data being set (i.e., from hours to minutes to seconds). The knob must be pressed and held for 2 seconds in order to set the clock data.

DIAL rotate—Clockwise rotation increases and counterclockwise rotation decreases the flashing digits on the screen.

RESET (10)—Resets the fuel timer, chrono, or note to zero. In approach mode, the first press recalls the last preset value, the second press resets the timer to zero. When setting clock, resets time to 12:00 PM.

LIGHT (12)—Toggles backlight on and off. Backlight will stay on for 5 minutes then shut off.

Alternate Functionality: **CLOCK**, **APPROACH**, and **NOTE** can also accept a flashing value rather than stepping all the way through using the DIAL push button.

CLOCK FUNCTION

The Flight Timer keeps track of the current time and provides three display options:

- ▶ Standard time (AM/PM)
- ▶ Military time (24-hour)
- ▶ Universal coordinated time (UTC or “Zulu”)

The “CLOCK” icon appears in the upper portion of the display when clock mode is active. If a different mode is active, press the CLOCK button to display the current time.

Display Formats

Press the CLOCK button to view the alternate display formats, standard with “AM” or “PM” (Figure 2), military (Figure 3) and UTC (Figure 4). UTC format displays hour digits associated with universal time, the minutes and seconds are identical to the other formats.



Figure 2—Standard 12-hour time format



Figure 3—Military time format



Figure 4—Universal coordinated time (UTC) format

Setting Time

- ▶ With standard or military time formats displayed, push and hold DIAL until the hour digits flash (about 2 seconds).

Trick—Press RESET at 0 seconds to reset to 12:00:00, then seconds will not need resetting later.

- ▶ Rotate DIAL to set the hours.
- ▶ Push DIAL. The minute digits will flash.
- ▶ Rotate DIAL to set the minutes.
- ▶ Push DIAL. The second digits will flash.
- ▶ Rotate DIAL to set the seconds.
- ▶ Push DIAL to finish setting time.

Setting UTC Hour

- ▶ With UTC time format displayed, push and hold DIAL until the hour digits flash (about 2 seconds).
- ▶ Rotate DIAL to set the hours.
- ▶ Push DIAL to finish setting UTC hour digits.

FUEL TIMER FUNCTION

The Flight Timer includes a fuel timer function to time the intervals between fuel tank selections or other intermittent events. Fuel timer features include:

- ▶ Up to 99-hour timer
- ▶ Count-up or countdown operation
- ▶ Audible and visible countdown alarm
- ▶ Operates independently from other timers and clock

The “FUEL” icon appears in the upper portion of the display when fuel mode is active. If a different mode is active, press the FUEL/CHRONO button to display the fuel timer.



Figure 5—Fuel timer display

Count-up Operation

Count-up operation can be used to track the duration of events up to 99 hours and 59 minutes long. No alarm will sound when counting up.

- ▶ If timer is running press START/STOP to stop timer.
- ▶ Press RESET to zero timer as shown in Figure 5.
- ▶ Press START/STOP to start timer. Seconds will begin to count up.
- ▶ Press START/STOP to stop timer.

Countdown Operation

Countdown operation can be used to time the interval between events. A beeping alarm, flashing icons and backlight notify the user that time has elapsed.

- ▶ If timer is running press START/STOP to stop timer.
- ▶ Press RESET to zero timer as shown in Figure 5.
- ▶ Push DIAL. The hour digits will flash.
- ▶ Rotate DIAL to set hours.
- ▶ Push DIAL. The minute digits will flash.
- ▶ Rotate DIAL to set minutes.
- ▶ Push DIAL. The second digits will flash.
- ▶ Rotate DIAL to set seconds.
- ▶ Push DIAL to save.

Fuel Timer Alarm

When the fuel timer counts down to zero the Flight Timer sounds an audible and visible alarm then begins to count up, measuring the time since the alarm. If fuel mode is active, the hour, minute and second digits flash. If another mode is active, the "FUEL" icon flashes to indicate a fuel timer alarm. The audible alarm and flashing backlight cease after 10 seconds or when the alarm is canceled.

Canceling the Fuel Timer Alarm

- ▶ If a mode other than fuel is active, press FUEL/CHRONO.
- ▶ Press START/STOP to stop flashing digits.
- ▶ Elapsed time since alarm is maintained on screen.

CHRONOGRAPH FUNCTION

The Flight Timer includes a chronograph (stopwatch) function for precise measurement of time intervals. The features of this timer are:

- ▶ Count-up measurement only.
- ▶ Precise 1/10th and 1/100th second digit display.
- ▶ Counts up to 99 minutes.
- ▶ Operates independently from other timers and clock.

The “CHRONO” icon appears in the upper portion of the display when chronograph mode is active. If a different mode is active, press the FUEL/CHRONO button to display the chronograph timer.

Chronograph Operation

- ▶ Press RESET to zero timer as shown in Figure 6.
- ▶ Press START/STOP to start chronograph.
- ▶ Press START/STOP to stop chronograph.
- ▶ Press START/STOP again to restart from same point or RESET to zero.



Figure 6—Chronograph (stopwatch) display

APPROACH TIMER FUNCTION

The Flight Timer includes an approach timer function to time approach intervals. For convenience, multiple approach times can be programmed prior to flight. Features include:

- ▶ Count-up or countdown operation.
- ▶ Up to 59-minute 59-second timer.
- ▶ Stores 6 home (H) airport approach times.
- ▶ Stores 6 destination (D) airport approach times.
- ▶ Preset approach times can be recalled with the push of a button.
- ▶ Audible and visible countdown alarm.
- ▶ Operates independently of other timers and clock.

The “APPROACH” icon appears in the upper portion of the display when approach mode is active. If a different mode is active, press the APPROACH button to display the approach timer.



Figure 7—Approach timer display

Selecting an Approach Time

There are 12 approach times stored in memory. Six are labeled H1, H2, H3, H4, H5, H6 and six are labeled D1, D2, D3, D4, D5, D6. Rotate the DIAL to view these one at a time. In a new timer, they will all be zero.

Count-up Operation

Count-up operation can be used to track the duration of events. No alarm will sound when counting up.

- ▶ If timer is running press START/STOP to stop timer.
- ▶ Press RESET to zero timer as shown in Figure 7.
- ▶ Press START/STOP to start timer. Seconds will begin to count up.
- ▶ Press START/STOP to stop timer.

Countdown Operation

Countdown operation can be used to time the interval between events. A beeping alarm, flashing icons and backlight notify the user that time has elapsed.

- ▶ If timer is running press START/STOP to stop timer.
- ▶ Rotate DIAL to select an approach time (H1-H6 or D1-D6).
- ▶ Push DIAL. The minute digits will flash.
- ▶ Rotate DIAL to set minutes.
- ▶ Push DIAL. The second digits will flash.
- ▶ Rotate DIAL to set seconds.
- ▶ Push DIAL to save or push START/STOP to start timer directly.
- ▶ START/STOP starts the timer counting down. Once started, it is not possible to reach other approach times.

APPROACH TIMER ALARM

When the approach timer counts down to zero the Flight Timer sounds an audible and visible alarm then begins to count up, measuring the time since the alarm. If approach mode is active, the hour, minute and second digits flash. If another mode is active, the “APPROACH” icon flashes to indicate an approach timer alarm. The audible alarm and flashing backlight cease after 10 seconds or when the alarm is canceled.

Canceling the Approach Timer Alarm

- ▶ If a mode other than approach is active, press the APPROACH button.
- ▶ Press START/STOP to stop flashing digits.
- ▶ Time since alarm is maintained on screen.

Recalling Stored Approach Times

With the approach timer stopped:

- ▶ Press RESET to recall the last saved time.
- ▶ Pressing RESET a second time clears the memory location.
- ▶ Alternatively the DIAL can be rotated away from then back to the current memory location to recall the last saved time.

NOTE/SCRATCHPAD FUNCTION

The Flight Timer includes a 5-digit numeric note displayed in the upper right corner of the LCD. Use it as a scratchpad for remembering important flight numbers such as approach altitudes, frequencies, or squawk codes. This note is always displayed and can be accessed from any mode as follows:

- ▶ Press NOTE. The two highest digits will flash.
- ▶ Rotate DIAL to set first two digits.
- ▶ Push DIAL. The hundreds digit will flash.
- ▶ Rotate DIAL to set the hundreds digit.
- ▶ Push DIAL. The tens digit will flash.
- ▶ Rotate DIAL to set the tens digit.
- ▶ Push DIAL. The ones digit will flash.
- ▶ Rotate DIAL to set the ones digit.
- ▶ Push DIAL to accept note.
- ▶ Also, pressing NOTE at any time while setting will accept the current note value.

BACKLIGHT OPERATION

The Flight Timer includes a LED backlight system for night visibility. Toggle on and off by pressing the LIGHT button. If left on, the backlight will automatically shut itself off after 5 minutes. Prior to auto shut-off, the backlight will flash ten times to announce that it is shutting off. Use of the backlight greatly increases battery drain (see specifications for details). For extended battery life, avoid excessive use of the backlight.

DEVICE RESET

The Flight Timer includes a user enabled reset in case of malfunction. Press and hold NOTE and START/STOP for several seconds to reset the device. Under normal use, avoid holding these buttons simultaneously since the reset clears the clock, timers and approach memories.

CARE

The ASA Flight Timer will provide years of service if cared for properly. We suggest that you:

1. Avoid drops or shocks to the unit that could damage the case or screen.
2. Protect your timer from dirt, dust, and water.
3. Clean with a damp cloth; do not submerge in water.
4. **Avoid exposure to extreme temperatures. Do not leave your timer exposed in the aircraft on sunny days. Take it with you.**

SPECIFICATIONS

Voltage: 3V DC supplied by 2 AAA batteries

Current (backlight off): 40 μ A typical

Current (backlight on): 1.8 mA typical

Expected battery life (no backlight use): >2 years

Expected battery life (continuous backlight use): >400 hours

Service temperature range: -4°F to 130°F (-20°C to 54°C)

LIMITED WARRANTY

Aviation Supplies & Academics, Inc. (ASA) warrants this ASA Flight Timer to the original purchaser for a period of five years from the initial date of purchase, against defects in material and workmanship. Batteries are not covered by this warranty.

For the above five-year limited warranty period, ASA will either amend or substitute a reconditioned model of identical quality (at ASA's option), provided the product is returned postage prepaid to ASA. In the event of substitution with a reconditioned model, the warranty of the original instrument will be upheld. Other than the above requirements, repair, adjustments and/or substitutions will be made at no charge.

ASA strives to provide the most rugged and reliable equipment possible. So few items are received for repair that it is not economical to maintain parts inventory, test equipment, and trained repair technicians to perform electronic repair work. Therefore, a replacement unit (new or remanufactured) is sent in exchange for units returned for service or repair.

ASA will not be liable for lapse of use of the instrument or other secondary or sequential costs, expenditures, or damages brought about by the purchaser. Implied warranties originating out of this sale, including but not limited to the implied warranties of merchantability and fitness for a particular purpose, are limited in duration to the above five-year period. ASA shall not be liable for loss of use of the instrument or other incidental or consequential costs, expenses, or damages incurred by the purchaser.

Some states do not allow the exclusion or limitation of implied warranties or consequential damages; so, the above limitations or exclusions may not apply to you.

Record the purchase date in the space provided below. Refer to this when contacting ASA regarding this product.

The ASA Flight Timer is an instruction and pilot information aid, and is not an avionics instrument.

Purchase Date: _____

US Pat. No. 7,187,303

Made in China



Aviation Supplies & Academics, Inc.

7005 132nd Place SE

Newcastle, Washington 98059 USA

425-235-1500 | asa2fly.com

TIMER-3