

Fly the Wing

The following changes provide updates to information printed in the fourth edition of *Fly the Wing*. Each entry below signals a change or addition to the text.

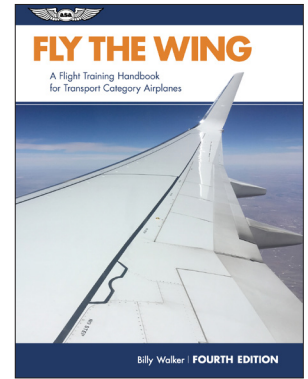

Page 58: *Figure 8-1 is replaced with the following (credit: Richard Boll)*

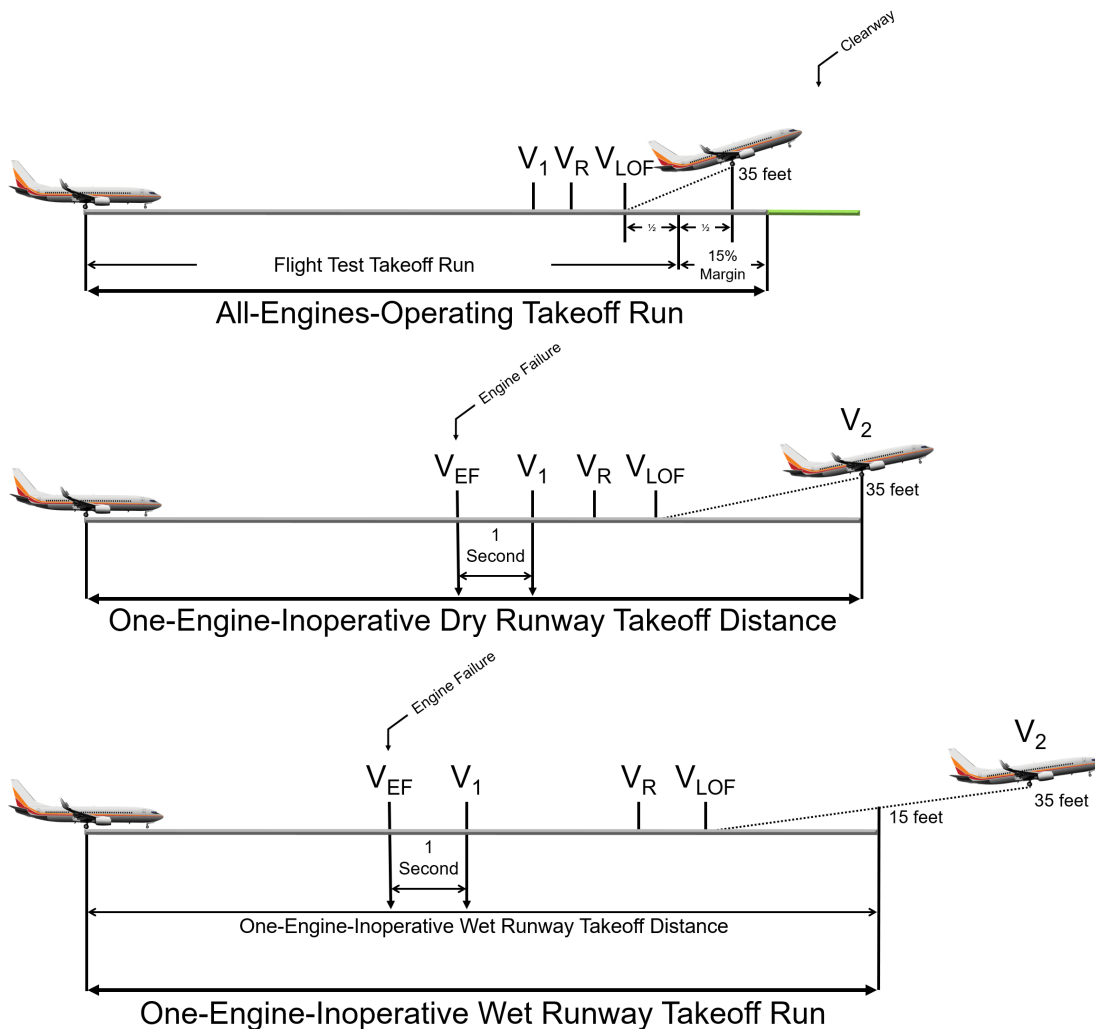
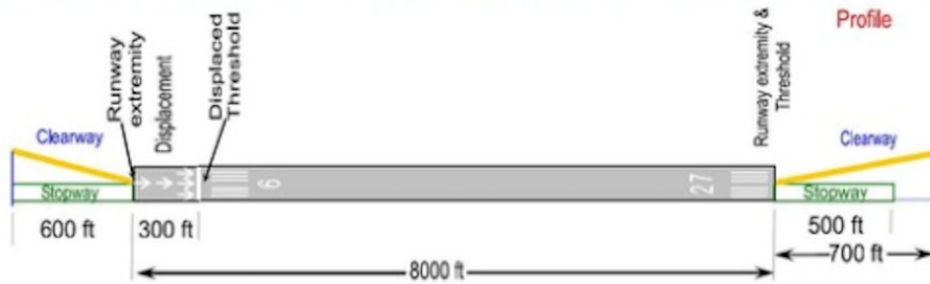
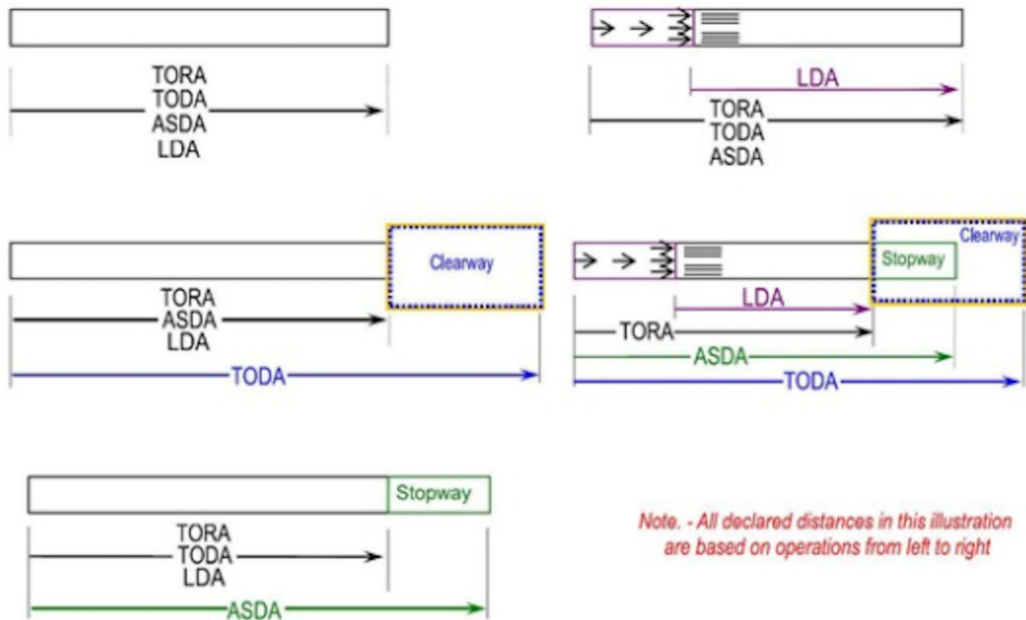

Figure 8-1. Minimum required takeoff runway length without use of a clearway or stopway.

(Continued)

Declared Distances with Full Standard Runway Safety Areas, Runway Object Free Areas, and Runway Protection Zones



Runway	Length (feet)	TORA	ASDA	TODA	LDA
9	8000	8000	8500	8700	7700
27	8000	8000	8600	8600	8000

Note: ASDA = Accelerate/Stop Distance Available
 TORA = Takeoff Run Available
 TODA = Takeoff Distance Available
 LDA = Landing Distance Available

Figure 8-2. Minimum required takeoff runway length utilizing a clearway and/or stopway.

(Continued)

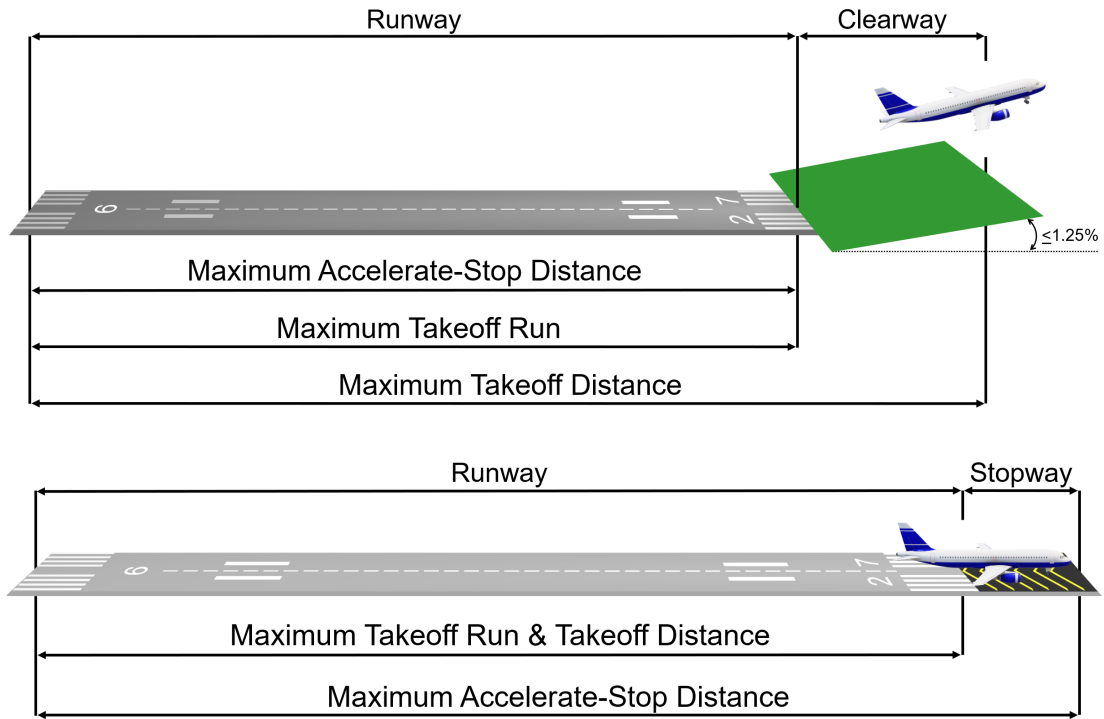

[Author please provide caption]

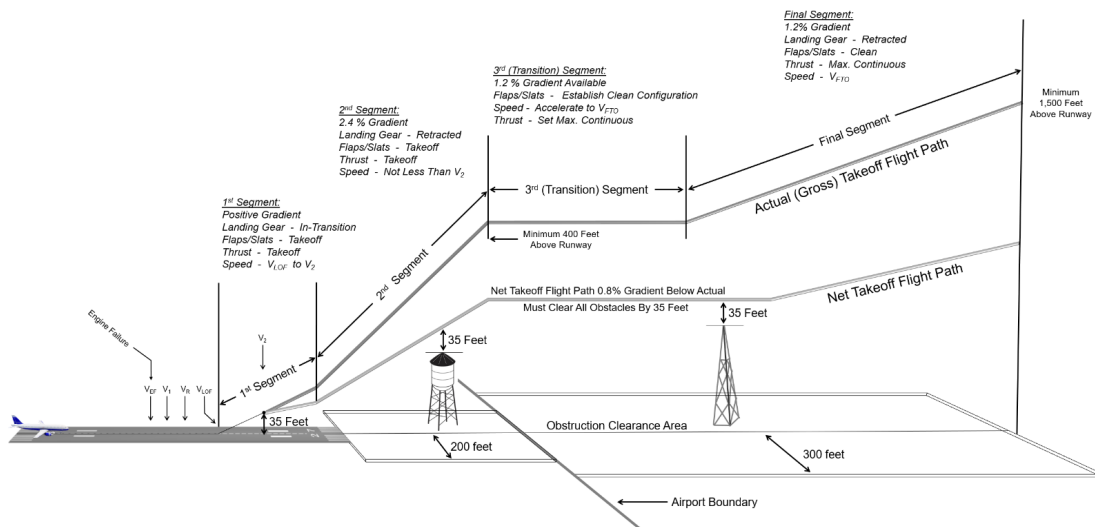

Figure 8-5. Takeoff flight path profile.